

where eq 12 is obtained with the appropriate manipulation of eq 10 and 11. The carbene scheme yields an unacceptably high E_a estimate of 2.5 eV. This can be expected qualitatively, since the formation of C_A^0 requires the disruption of two carbon-carbon π bonds.¹⁵ The radical scheme gives a quite reasonable E_a estimate and from these simple energetic considerations would seem to be the most reasonable conceptualization of the polymerization mechanism.³⁴ Though these arguments obviously oversimplify the problem, we believe that the direction for future theoretical calculations of the energetics and pathway for diacetylene polymerization is clearly indicated.

Acknowledgments. We gratefully acknowledge helpful discussions with R. H. Baughman, D. M. Lemal, M. J. S. Dewar, and R. J. Silbey.

References and Notes

- G. Wegner, *Z. Naturforsch. B*, **24**, 824 (1974).
- G. Wegner, *Makromol. Chem.*, **134**, 219 (1970).
- G. Wegner, *Makromol. Chem.*, **145**, 85 (1971).
- E. Hadicke, E. C. Mez, C. H. Krauch, G. Wegner, and J. Kaiser, *Angew. Chem.*, **83**, 253 (1971).
- D. Day and J. B. Lando, *J. Polym. Sci., Polym. Phys. Ed.*, in press; V. Enkleman and J. B. Lando, *Acta Crystallogr.*, in press.
- D. Kobelt and E. F. Paulus, *Acta Crystallogr., Sect. B*, **30**, 232 (1973).
- P. A. Apgar and K. C. Yee, *Acta Crystallogr., Sect. B*, **34**, 957 (1978).
- R. R. Chance, R. H. Baughman, H. Müller, and C. J. Eckhardt, *J. Chem. Phys.*, **67**, 3616 (1977).
- Z. Iqbal, R. R. Chance, and R. H. Baughman, *J. Chem. Phys.*, **66**, 5520 (1977).
- D. Bloor, D. N. Batchelder, and F. H. Preston, *Phys. Status Solidi A*, **40**, 279 (1977), and references cited therein.
- J. Knecht, B. Reimer, and H. Bässler, *Chem. Phys. Lett.*, **49**, 327 (1977), and references cited therein.
- D. Bloor, L. Koski, G. C. Stevens, F. H. Preston, and D. J. Ando, *J. Mater. Sci.*, **10**, 1678 (1975).
- G. C. Stevens and D. Bloor, *J. Polym. Sci., Polym. Phys. Ed.*, **13**, 2411 (1975).
- R. R. Chance and J. M. Sowa, *J. Am. Chem. Soc.*, **99**, 6703 (1977).
- R. R. Chance and G. N. Patel, *J. Polym. Sci., Polym. Phys. Ed.*, **16**, 859 (1978).
- E. M. Barrall, T. C. Clarke, and A. R. Gregges, *J. Polym. Sci., Polym. Phys. Ed.*, in press.
- See, for example, P. Peyser and W. D. Bascorn, *J. Appl. Polym. Sci.*, **21**, 2359 (1977), and references cited therein.
- R. R. Chance, G. N. Patel, E. A. Turi, and Y. P. Khanna, *J. Am. Chem. Soc.*, **100**, 1307 (1978).
- A. F. Preziosi, unpublished results.
- J. S. Ghota, G. C. Stevens, and D. Bloor, *J. Polym. Sci., Polym. Chem. Ed.*, **15**, 1155 (1977).
- R. H. Baughman, *J. Chem. Phys.*, **68**, 3110 (1978).
- A. R. McGhie, P. S. Kalyanaraman, and A. F. Garito, *Bull. Am. Phys. Soc.*, **23**, 408 (1978); *J. Polym. Sci., Polym. Lett. Ed.*, **16**, 335 (1978).
- G. N. Patel, to be published.
- This increase in melting point was also observed by Barrall, et al.¹⁶ on a single sample preannealed for 14 h at 333 K [$P(t) \sim 0.032$; $T_m \sim 375$ K]. They incorrectly concluded that this indicated the presence of a "new high temperature phase which acts as the monomer form for the bulk of the reaction". This is clearly not the case since T_m increases monotonically with conversion. This increase is undoubtedly a consequence of the fact that there is solid solution formation at all conversions in PTS.^{21,23}
- G. Wegner, *Z. Naturforsch. B*, **24**, 824 (1969); J. Kiji, J. Kaiser, G. Wegner, and R. Schulz, *Polymer*, **14**, 433 (1973).
- K. C. Yee and R. R. Chance, *J. Polym. Sci., Polym. Phys. Ed.*, **16**, 431 (1978).
- R. R. Chance and R. H. Baughman, Eighth Molecular Crystals Symposium Abstracts, Santa Barbara, Calif., 1977, p 47.
- M. J. S. Dewar, "Hyperconjugation", Ronald Press, New York, N.Y., 1962, p 66.
- Consideration of the actual bond lengths in the monomer crystals is not necessary, since numerous structure determinations for diacetylenes have yielded bond lengths which are very similar to the typical values given by Dewar. See for example, A. W. Hanson, *Acta Crystallogr., Sect. B*, **31**, 831 (1975); T. Taga, N. Masaki, K. Osaki, and T. Watanabè, *Bull. Chem. Soc. Jpn.*, **44**, 2981 (1971).
- See, for example, R. M. Joshi and B. J. Zwolinski in "Vinyl Polymerization", Vol. 1, G. E. Ham, Ed., Marcel Dekker, New York, N.Y., 1967, p 445. It should be pointed out that large energetic differences between the acetylene and butatriene structures are not expected with these thermochemical calculations.³¹
- R. H. Baughman, unpublished results.
- R. B. Woodward and R. Hoffman, *Angew. Chem., Int. Ed. Engl.*, **8**, 781 (1969).
- See, for example, R. G. Pearson, "Symmetry Rules for Chemical Reactions", Wiley-Interscience, New York, N.Y., 1976, p 70.
- We should note here that a carbene chain end characteristic of C_A^0 has been observed in the polymerization of PTS (but interestingly only in the autocatalytic region).³⁵ As has been argued elsewhere,¹⁵ it is unlikely that the nature of the chain termination has any significant implications regarding the chain initiation event.
- G. C. Stevens and D. Bloor, *Chem. Phys. Lett.*, **40**, 37 (1976); P. Eichele, M. Schwoerer, R. Huber, and D. Bloor, *ibid.*, **42**, 342 (1976).

Electronic Excitation Energy Partitioning in Dissymmetric Dioxetane Thermolyses. The Absolute Chemiluminescence Yields and Triplet to Singlet Excited State Ratios for 3-Acetyl-4,4-dimethyl-1,2-dioxetane

Keith A. Horn and Gary B. Schuster*¹

Contribution from the Roger Adams Laboratory, School of Chemical Sciences, University of Illinois, Urbana, Illinois 61801. Received March 29, 1978

Abstract: 3-Acetyl-4,4-dimethyl-1,2-dioxetane (**3**) was prepared by the base-catalyzed rearrangement of 4-bromo-3-hydroxy-3,5,5-trimethyl-1,2-dioxolane (**2**). Thermal decomposition of dioxetane **3** to acetone and methylglyoxal proceeds with an activation energy of 26.0 ± 1.0 kcal/mol and a log A of 14.2. The enthalpy of activation and entropy of activation were determined to be 25.5 ± 1.0 kcal/mol and 4.0 ± 2.0 eu, respectively. The total yield of excited states produced in the thermal decomposition was determined to be $17 \pm 3\%$. Both excited-state acetone and excited-state methylglyoxal were detected. The excited-state multiplicities and yields follow: acetone triplet, $0.45 \pm 0.20\%$; methylglyoxal singlet, $1.6 \pm 0.5\%$; and methylglyoxal triplet, $15 \pm 3\%$. No singlet excited state acetone was detected. We suggest that the observed excited-state yields and the low triplet to singlet excited-state methylglyoxal ratio can best be rationalized in terms of the energetics of a stepwise biradical decomposition of the dioxetane **3**.

Prerequisite to the logical design of efficient chemiluminescent systems is the detailed knowledge of the fundamental excitation steps in known chemiluminescent processes. The

study of the unimolecular thermal decomposition of 1,2-dioxetanes,² subsequent to the isolation and characterization of the first dioxetane in 1969,³ has provided considerable in-

sight into the chemistry of this ring system. Primary emphasis in the study of the excitation process in 1,2-dioxetanes has been given to the determination of those factors (energetic, geometric, Franck-Condon) which control the total excited-state yield and the ratio of triplet to singlet excited-state products. Any postulated excitation mechanism must account for the relatively high activation energies, the efficient production of $n\pi^*$ excited state carbonyl-containing products, and the high triplet to singlet excited-state ratios observed for nearly all alkyl- or phenyl-substituted 1,2-dioxetane thermal decompositions.⁴

The behavior of 1,2-dioxetanes along the reaction coordinate leading to excited-state product has been a matter of considerable debate between proponents of a concerted decomposition⁹ and those favoring formation of an intermediate biradical. Recently, experimental evidence has accumulated in favor of the excitation mechanism involving initial cleavage of the oxygen-oxygen bond to form a 1,4-biradical which then partitions between excited- and ground-state carbonyl-containing products. The evidence supporting this mechanism includes activation parameters and thermochemical data for variously substituted dioxetanes¹⁰ as well as the absence of a measurable secondary deuterium isotope effect in the thermal decomposition of *trans*-3,4-diphenyl-1,2-dioxetane.¹¹ This latter observation clearly demonstrates that the hybridization of the ring carbons is not changing during the rate-determining step of this reaction. In addition, differential quenching experiments have been interpreted to be consistent with a 1,4-biradical intermediate on the path to electronically excited state products.¹² The detailed ab initio GVB-CI calculations of Goddard and Harding¹³ also concur with a biradical decomposition pathway for dioxetane in which the ground state of dioxetane crosses three triplet states on opening to the *trans* or *gauche* biradical.

The suggestion that the nature of the excited state of the product ($n\pi^*$ vs. $\pi\pi^*$, the amount of charge transfer character, the relative energies, etc.) influences the transition state and thereby the partitioning of electronic energy and the triplet to singlet excited state ratios in 1,2-dioxetane decompositions has recently appeared. For example, charge transfer interactions¹⁴ in the excited-state products have been suggested to account for the high singlet yields from *p*-dimethylamino-substituted 1,6-diaryl-2,5,7,8-tetraoxabicyclo[4.2.0]octanes.¹⁵ In addition, the formation of $n\pi^*$ excited states has been suggested to be kinetically preferred in the thermal decomposition of the dioxetanes **1a-e** studied by Zimmerman et al.¹⁶ The efficiency

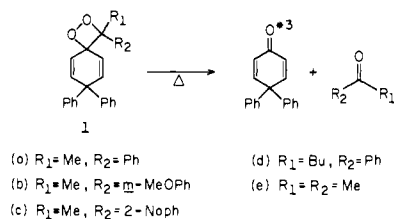

for generation of the dienone triplet from the thermal decomposition of **1a-e** was found to be independent of the identity of the second carbonyl fragment even though the energy of the $\pi\pi^*$ triplet of the 2-acetonaphthone (59 kcal/mol) from **1c** is lower than the energy of the $n\pi^*$ triplet of the dienone (69 kcal/mol). However, no attempt was made to detect 2-acetonaphthone excited states. The $n\pi^*$ nature of the dienone triplet was suggested as the critical controlling factor in the regio-specificity and efficiency of excited-state generation.

One could potentially learn a great deal about the effect product excited state energies have on the transition state, the total yield of excited states, and the triplet to singlet excited state ratios through the investigation of dioxetane decompositions in which the two $n\pi^*$ excited states produced in the

fragmentation differ energetically, chemically, and spectrally. Though several dissymmetric dioxetanes have been prepared and studied,^{3,10a,10b,17} none has been investigated in sufficient quantitative detail to examine the partitioning of the excitation energy between the different fragment species. We report here the excited-state yields and multiplicities from the thermal decomposition of the dissymmetric 3-acetyl-4,4-dimethyl-1,2-dioxetane (**3**).

Results and Discussion

1. Preparation and Characterization of Dioxetane 3. Dioxetane **3** was prepared in two steps from mesityl oxide as outlined in eq 1 and detailed in the Experimental Section. Reaction of mesityl oxide with anhydrous hydrogen peroxide and 4-bromo-3,5-dimethylhydantoin resulted in an 80% yield of 4-bromo-3-hydroxy-3,5,5-trimethyl-1,2-dioxolane (**2**) consisting of a 60:40 mixture of two diastereomers. Rapid mixing of a dichloromethane solution of the mixture of diastereomers with potassium *tert*-butoxide at 10 °C followed by chromatography at -22 °C resulted in a 9% yield of pure **3**. Carbon tetrachloride or acetonitrile solutions of **3** are essentially indefinitely stable at -20 °C in the dark. Attempts to crystallize **3** were unsuccessful. The ¹H NMR is clearly con-

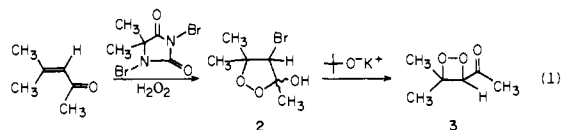

sistent with **3**, showing one methine singlet (δ 4.92) and three methyl singlets (δ 2.40, 1.73, and 1.32). Carbon tetrachloride solutions of dioxetane **3** rapidly and quantitatively liberate iodine from 2-propanol/H₂O solutions of potassium iodide, indicative of the peroxidic nature of **3**. The IR absorption spectrum is also consistent with the structure assigned to **3**, having a carbonyl group absorption at 1725 cm⁻¹. The UV absorption spectrum is typical of other known 1,2-dioxetanes,¹⁸ exhibiting a maximum in carbon tetrachloride at 290 nm with an extinction coefficient at the maximum of 54 M⁻¹ cm⁻¹. The UV absorption spectrum is broad and structureless and exhibits a long-wavelength tail extending to ca. 450 nm. Further characterization of **3** was accomplished by reaction with triethylphosphite to give the relatively unstable phosphorane **4** as shown in eq 2. The phosphorane was characterized by its

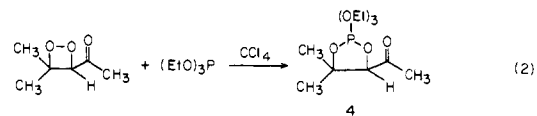

220-MHz ¹H NMR spectrum. Thermolysis of **3** in base-washed glassware at room temperature proceeds cleanly to give acetone and methylglyoxal as the only products (eq 3). The

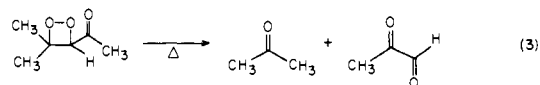

ratio of acetone to methylglyoxal did not remain constant over the time period of the thermal decomposition because of the instability of methylglyoxal under these conditions. Therefore, the ratio of the amounts of acetone to methylglyoxal (determined by NMR integration at various times over several half-lives) formed was extrapolated to zero reaction time. The ratio of the yield of acetone to methylglyoxal was found to be equal to one at low conversion.

2. Chemiluminescence from the Thermolysis of 3. The thermolysis of **3** in a variety of solvents results in easily detectable chemiluminescence. Shown in Figure 1 are emission spectra of the chemiluminescence during the thermal de-

Table I. Activation Parameters for the Thermolysis of Dioxetane 3

analysis	[3]	temp range, °C ^b	E_A , kcal/mol	ΔH^\ddagger , kcal/mol	ΔS^\ddagger , eu
Arrhenius ^a	9.92×10^{-6} M	46.90–64.80	26.4 ± 1.0		
initial chemiluminescence intensity ^a	5.33×10^{-5} M	24.80–41.00	25.7 ± 1.0		
Eyring ^{a,20}	9.92×10^{-6} M	46.90–64.80		25.5 ± 1.0	4.0 ± 2.0

^a Rates and initial chemiluminescence intensities were measured by monitoring the total light emission from **3** in air-saturated CCl₄ solution. ^b Constant cell temperature was maintained to within ± 0.1 °C.

Table II. Stern–Volmer Sensitization Data for the Thermolysis of Dioxetane 3

dioxetane	concn, M ^a	solvent	acceptor	$k_q\tau$, M ⁻¹	intercept
3	7.0×10^{-4}	CH ₃ CN ^b	DBA ^c	$1.54 \times 10^4 (\pm 9 \times 10^2)^e$	$4.0 \times 10^{-8} (\pm 2 \times 10^{-9})^f$
TMD	8.2×10^{-5}	CH ₃ CN ^b	DBA ^c	$4.25 \times 10^4 (\pm 1.8 \times 10^3)^e$	$1.71 \times 10^{-8} (\pm 4 \times 10^{-10})$
3	1.84×10^{-4}	benzene	rubrene ^d	$7.5 \times 10^2 (\pm 7 \times 10^1)$	$5.0 \times 10^{-8} (\pm 4 \times 10^{-9})$
TMD	1.93×10^{-3}	benzene	rubrene ^d	$1.9 \times 10^2 (\pm 8 \times 10^1)$	$3.7 \times 10^{-8} (\pm 1.5 \times 10^{-8})$

^a All determinations were made at 65.00 ± 0.1 °C. ^b CH₃CN solutions of dioxetanes were purged with N₂ for 3 min at 0 °C. ^c Integrated chemiluminescence intensities were obtained by monitoring the DBA fluorescence at 430 nm. ^d Integrated chemiluminescence intensities were obtained by monitoring the rubrene fluorescence at 575 nm. ^e The lifetime of triplet excited acetone in CH₃CN at 65.00 °C was found to be subject to minor variation due to trace amounts of impurities. ^f All errors are standard deviations.

composition of **3** in air-saturated and nitrogen-purged acetonitrile. The fluorescence and phosphorescence emissions observed in either carbon tetrachloride or acetonitrile have maxima at 465 and 525 nm, respectively. The spectra exhibit fine structure similar to those of photoexcited biacetyl and agree well with the gas-phase emission spectra for methylglyoxal reported by Colveleskie and Yardley.¹⁹ Hence, the emitting species formed during the thermolysis was identified as electronically excited methylglyoxal. There is no readily detectable emission from excited-state acetone between 400 and 430 nm in nitrogen-purged acetonitrile solutions of **3**.

The activation energy (E_A) for the thermal decomposition of **3** was determined in carbon tetrachloride by two different techniques. First, the rate of decomposition of dioxetane **3** was determined at several temperatures by monitoring the decay of the chemiluminescence intensity resulting from methylglyoxal fluorescence. A standard Arrhenius plot of the derived first-order rate constants gave an activation energy of 26.4 ± 1.0 kcal/mol and a preexponential factor of $10^{14.2}$ ($\Delta H^\ddagger = 25.5 \pm 1.0$ kcal/mol, $\Delta S^\ddagger = 4.0 \pm 2.0$ eu). Second, the temperature dependence of the initial chemiluminescence intensity²⁰ was used to determine the activation energy for the fraction of the total reaction which leads to chemiluminescence. A least-squares analysis of these data gave an activation energy of 25.7 ± 1.0 kcal/mol. These results indicate that the path leading to excited-state methylglyoxal and that leading to ground-state methylglyoxal have the same rate-determining step. These data are summarized in Table I.

3. Nature of the Excited States from the Thermal Decomposition of 3. The nature and yields of excited-state carbonyl products resulting from the thermal decomposition of dioxetane **3** were determined using both indirect chemiluminescence techniques and a sensitized chemical reaction. Thermal decomposition of **3** in the presence of 9,10-dibromoanthracene (DBA) in carbon tetrachloride or acetonitrile solution results in emission from the fluorescent singlet state of DBA detected at 430 nm. The dependence of the enhanced chemiluminescence intensities on the concentration of added DBA was found to follow a Stern–Volmer relationship. The intercept and $k_q\tau$ values are given in Table II. The observed lifetime of the excited state which is quenched by DBA (calculated from the intercept to slope ratio by assuming a diffusion-controlled rate of quenching by DBA of 1×10^{10} M⁻¹ s⁻¹) is 2×10^{-6} s. Consideration of the four potential excited states that may result from the thermal decomposition of dioxetane **3** (the singlet and triplet excited states of acetone and methylglyoxal)

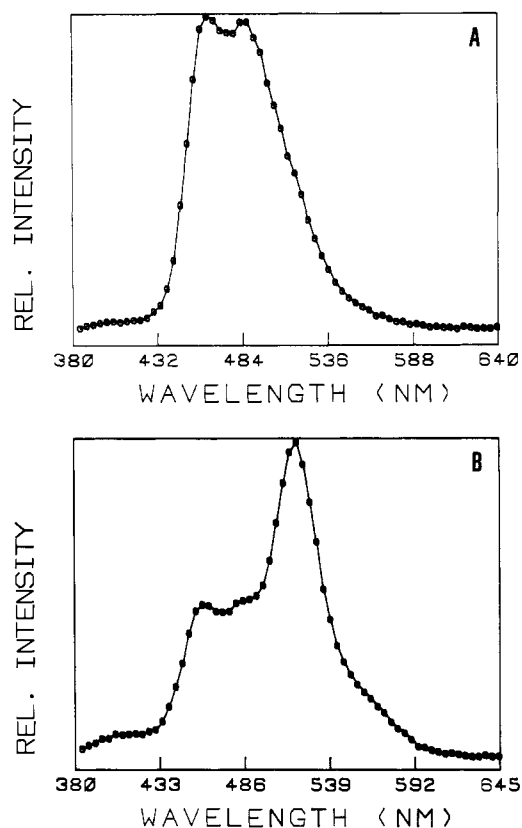

Figure 1. Chemiluminescence emission spectra for dioxetane **3** in acetonitrile solution: (A) fluorescence; (B) phosphorescence.

suggests three thermodynamically feasible pathways for the formation of the first excited singlet state of DBA. These reaction pathways are presented in eq 4–6 (see Figure 2).

A series of experiments was carried out in order to distinguish between the excitation pathways shown in Figure 2. Significantly, decomposition of dioxetane **3** in the presence of 3.5×10^{-3} M 9,10-diphenylanthracene (DPA) does not result in any emission at 430 nm even though the quantum yield of fluorescence of DPA is approximately ten times that of DBA.²¹ Thus, no detectable excited acetone singlet is formed from the thermal decomposition of dioxetane **3** and direct singlet to singlet energy transfer from acetone singlet to DBA, as in eq

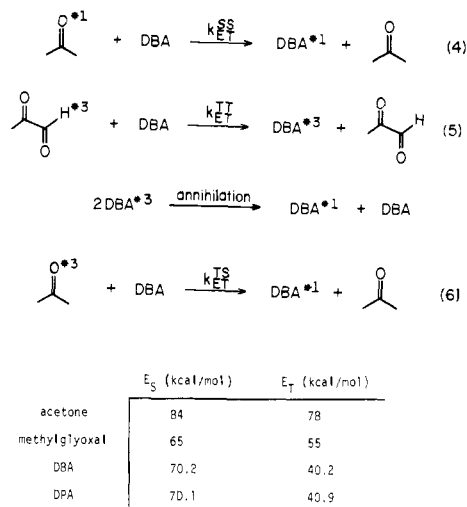
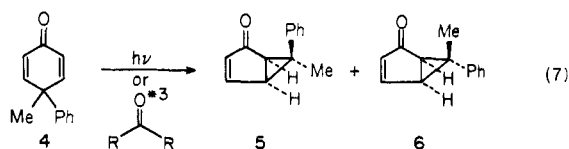

Figure 2. Thermodynamically feasible pathways for the information of the excited singlet state of DBA.

4, is ruled out as the mechanism for sensitizing the indirect chemiluminescence from DBA. Moreover, the microsecond lifetime determined from the Stern-Volmer sensitization data is consistent only with trapping of a triplet excited state.

Triplet to triplet energy transfer from excited triplet methylglyoxal to the low-lying $\pi\pi^*$ triplet of DBA ($E_T = 40.2$ kcal/mol)²² followed by DBA triplet-triplet annihilation to produce DBA singlet as in eq 5 is also not operational. This is indicated by the absence of an emission from the fluorescent singlet state of DPA. DPA also has a low-energy triplet excited state ($E_T = 40.9$ kcal/mol)²² approximately 15 kcal/mol below the lowest $n\pi^*$ triplet state of methylglyoxal ($E_T = 55$ kcal/mol).¹⁹ In light of the absence of an induced fluorescent emission from DPA in the presence of **3**, we do not consider the pathway in eq 5 responsible for the generation of singlet DBA.

The remaining energetically feasible route for production of the first excited singlet of DBA during the thermal decomposition of dioxetane **3** is triplet to singlet energy transfer from triplet acetone to DBA as is shown in eq 6. It is well known that excited triplet carbonyl compounds can transfer their excitation energy to DBA by a triplet to singlet energy transfer mechanism.^{23,24} Our results are consistent with this path for the excitation of DBA. First, the 2- μ s lifetime calculated from the Stern-Volmer data is consistent with that of triplet acetone in nitrogen-purged acetonitrile.²⁵ Further, DPA is ca. 1000 times less efficient an acceptor of triplet energy via the triplet to singlet energy transfer process than is DBA.^{2,23} Hence the lack of a detectable emission with DPA is clearly understood. Confirmation that acetone excited triplets are indeed formed from the thermolysis of dioxetane **3** in spite of the availability of the much lower lying methylglyoxal $n\pi^*$ triplet state was obtained through the dioxetane-sensitized reaction of 4-methyl-4-phenylcyclohexadienone (eq 7).²⁶ These results (see



following discussion) indicate that during the thermal decomposition of **3**, the excitation energy is partitioned between the two fragment molecules, acetone and methylglyoxal.

4. Yield of Acetone Triplet from the Thermolysis of 3. Clearly there are two reaction pathways available to the excited triplet

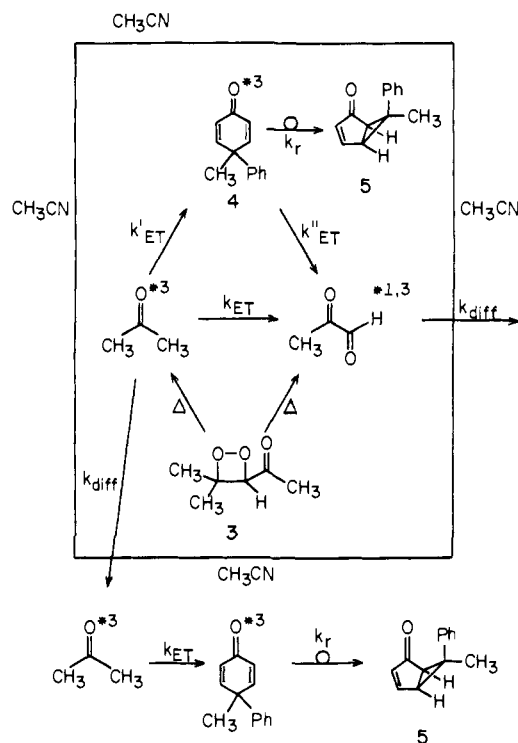

Figure 3. Pathways for energy transfer in the thermolysis of dioxetane **3** in the presence of 4-methyl-4-phenylcyclohexadienone (**4**).



acetone produced from thermolysis of dioxetane **3**. The first is diffusion out of the solvent cage into the bulk solution. The alternative pathway involves triplet to triplet energy transfer from excited triplet acetone to the methylglyoxal with which it is simultaneously produced (see Figure 3). This energy transfer is exothermic by approximately 23 kcal/mol and therefore its rate constant (k_{ET}) is expected to be large. The microsecond lifetime for the excited species determined from the DBA Stern-Volmer sensitization data indicates that the triplet acetone we have detected is that which has escaped the solvent cage in which it was generated. The detection of free or diffused triplet acetone by the indirect chemiluminescence of DBA suggests that the rate constant for diffusion (k_{diff}) is at least competitive with the in-cage triplet to triplet energy transfer. This conclusion is consistent with the findings of Wagner and of Liu in which the efficiency of in-cage energy transfer was ca. 30% in low-viscosity solvents.²⁸

The yield of triplet acetone produced in the thermal decomposition of **3** was determined by direct comparison with tetramethyldioxetane using two independent methods.

First, since the yield of triplet acetone from tetramethyldioxetane is now well established to be ca. 30%,²⁹ comparison was made between the total integrated luminescence intensities from the sensitized DBA emission measured at 430 nm³⁰ from both dioxetanes. The double reciprocal plots of chemiluminescence intensity against DBA concentration for both dioxetanes were extrapolated to infinite DBA concentration. The $k_q\tau$ and intercept values from this analysis are listed in Table II. The total integrated light intensity at infinite DBA concentration for **3** is $(1.4 \pm 0.5) \times 10^{-2}$ times that for tetramethyldioxetane. Using the reported quantum efficiency for triplet acetone formation from tetramethyldioxetane,²⁹ the triplet acetone yield from **3** is calculated to be (0.45 \pm 0.20)%.

Second, the acetone-sensitized type A rearrangement of 4-methyl-4-phenylcyclohexadienone (**4**) was used to measure the total yield of excited-state acetone,³¹ i.e., the sum of the triplet acetone which diffuses out of the cage and that which

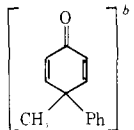
Table III. Yield of Triplet Excited Acetone from the Thermolysis of Dioxetane **3** Determined by the Sensitized Reaction of 4-Methyl-4-phenylcyclohexadienone (**4**)

dioxetane	concn, M ^a	temp, °C	[] ^b	M	yield  , %
TMD	0.203	76.0	1.48		30 ²⁹
3	0.204	76.0	1.39		0.51 ^c
3	0.203	76.0	1.41		0.47 ^c
TMD	0.170	72.0	1.54		30 ²⁹
3	0.227	72.0	0.77		0.39 ^c
3	0.136	72.0	3.01		0.46 ^c

^a All determinations were made in CH₃CN. ^b The molar concentrations are corrected for the solution volume change upon dissolution in CH₃CN. ^c Yields were determined by monitoring the yield of lumiketone **5** from both dioxetanes by gas chromatography with bi-phenyl as internal standard.

energy transfers and appears as excited triplet methylglyoxal. Dioxetane **3** was thermolyzed in acetonitrile solution in the presence of **4** at concentrations where on a statistical basis each molecule of dioxetane **3** is constantly in contact with at least one molecule of the dienone **4**. The yield of the type A rearrangement product, lumiketone **5**, was determined by gas chromatography. Direct comparison of the yields of lumiketone **5** from the thermolysis of dioxetane **3** was made with those from the thermolysis of tetramethyldioxetane under identical conditions. The absolute yield of triplet acetone from **3** was then calculated using the reported quantum efficiency for acetone triplet formation from tetramethyldioxetane.²⁹ The triplet acetone yield thus determined is (reported in Table III) (0.46 ± 0.15)%, the same, within experimental error, as that determined by the extrapolation of the Stern-Volmer line to infinite DBA concentration. Whether the yield of triplet acetone determined by the chemical interception represents the total yield of directly produced triplet acetone or the yield of triplet acetone which escapes the solvent cage is dependent on the relative magnitudes of the rate of energy transfer from triplet acetone to **4**, the rate of the type A rearrangement, and the rate of energy transfer from **4** to methylglyoxal. These rate constants are represented in Figure 3 as k'_{ET} , k_r , and k''_{ET} , respectively. The energy transfer from triplet acetone to the dienone **4** is exothermic by approximately 10 kcal/mol and thus the rate constant (k'_{ET}) for this reaction should be comparable to the rate constant of energy transfer from triplet acetone to methylglyoxal (k_{ET}). In fact, on the basis of Franck-Condon factors, one might expect k'_{ET} to be larger than k_{ET} . The fate of the excitation energy, once it is transferred to the dienone **4**, depends on the ratio of the rate constant of the type A rearrangement (k_r) to the rate constant of back energy transfer to the methylglyoxal within the solvent cage (k''_{ET}). Pertinent to this question is the observation that the type A rearrangement of **4** is not quenched by 1.0 M piperylene.²⁶ Thus, the rate constant for the type A rearrangement (k_r) is greater than the rate constant for quenching (k_q) of the excited triplet dienone by piperylene, i.e., $k_r \geq 1 \times 10^{10} \text{ s}^{-1}$. This observation implies that the rate of the type A rearrangement is greater than the rate of energy transfer from **4** to methylglyoxal. Further, the triplet acetone yields showed little variation with the concentration of dienone **4** in the range of 0.8–3.0 M. Taken together, the above findings suggest that ca. 0.46% is the total yield of directly produced triplet acetone. Available experimental techniques do not allow us to establish further that the triplet acetone yield determined by the chemical trap is the total yield of triplet acetone which has been formed during thermolysis of dioxetane **3**.

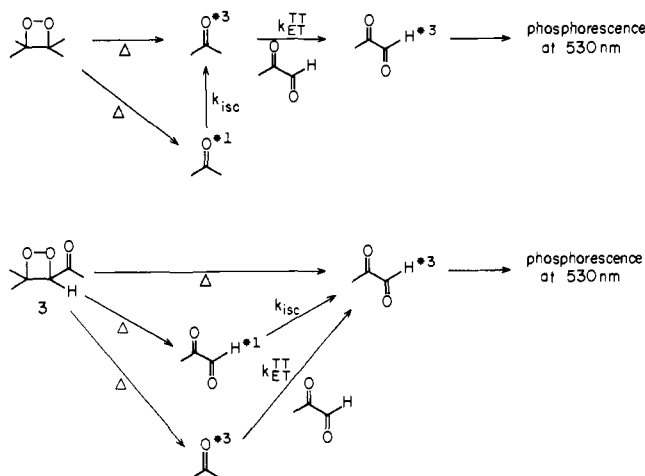
**Figure 4.** Kinetic pathways for the thermolysis of tetramethyldioxetane and dioxetane **3** in the presence of methylglyoxal.

5. Yield of Methylglyoxal Singlet from the Thermolysis of **3.** The thermal decomposition of **3** in air-saturated benzene solution in the presence of rubrene results in emission from the first excited singlet state of rubrene. The dependence of the enhanced chemiluminescence intensities on the concentration of added rubrene was found to follow a Stern-Volmer relationship.³² Since the quenching studies were carried out in air-saturated benzene, energy transfer from triplet species as well as triplet-triplet annihilation mechanisms for the formation of rubrene singlet were precluded. Methylglyoxal singlet therefore is implicated as the excited state responsible for the excitation of rubrene. Under identical conditions in air-saturated benzene solution, singlet acetone formed from thermolysis of tetramethyldioxetane is observed to transfer energy to rubrene forming rubrene excited singlet. Thus an estimate of the yield of excited singlet methylglyoxal from the thermolysis of **3** can be obtained by comparison with the yield of singlet excited acetone from tetramethyldioxetane. The double reciprocal plots of total integrated chemiluminescence intensity against rubrene concentration for both dioxetanes were extrapolated to infinite rubrene concentration. The intercepts and $k_q\tau$ -values are listed in Table II. The lifetimes³³ for the quenched species calculated from these Stern-Volmer sensitization data for tetramethyldioxetane and dioxetane **3** are consistent with those of acetone and methylglyoxal singlets, respectively. The total integrated light intensity at infinite rubrene concentration for **3** is 7.8 ± 2 times that for tetramethyldioxetane. Using a value of 0.002 as the quantum yield of formation of excited singlet acetone from tetramethyldioxetane,³⁴ the excited singlet methylglyoxal yield from **3** is calculated to be (1.6 ± 0.8)%. The most significant source of error in this determination is associated with the variation in the reported absolute yield of singlet acetone from the thermolysis of tetramethyldioxetane.

6. Total Yield of Excited States from the Thermolysis of **3.** The total yield of excited states produced by the thermolysis of **3** was determined relative to the yield of triplet excited acetone from thermolysis of tetramethyldioxetane. Conversion of the triplet acetone to methylglyoxal triplet by a triplet to triplet energy transfer made possible the direct comparison of the total integrated phosphorescence intensities³⁵ from both dioxetanes (see Figure 4). Since the ratio of the rate constant of intersystem crossing (k_{isc}) to the rate constant of fluorescence (k_f) is known to be large for the $n\pi^*$ excited states of carbonyl-containing compounds,³⁶ a direct comparison of intensities measures the combined total yield of the excited triplet acetone, singlet methylglyoxal, and triplet methylglyoxal (see

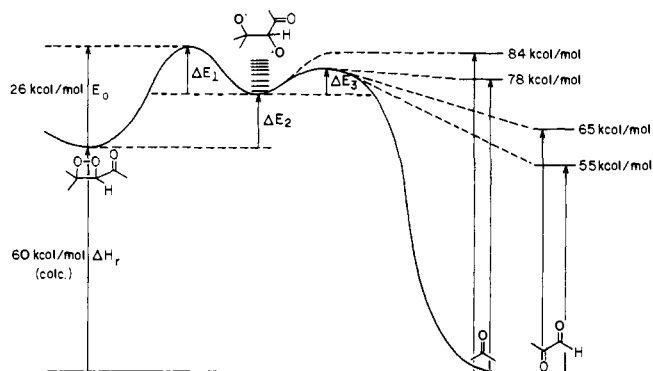

Figure 5. Energy profile for the thermally induced decomposition of dioxetane **3**.

Figure 4). A Stern–Volmer extrapolation to infinite methylglyoxal concentration for triplet acetone from tetramethyldioxetane could not be used since self-quenching by methylglyoxal has been reported to be significant even in the gas phase.¹⁹ Therefore, the direct comparison of intensities was made at a single concentration of added methylglyoxal. The efficiency for the energy transfer from triplet acetone to methylglyoxal (ϕ_{ET}) was calculated according to eq 8 where k_{ET}^{TT} is the rate constant for exothermic triplet to triplet energy transfer and k_d is the rate constant for the unimolecular deactivation of triplet acetone.

$$\phi_{ET} = \frac{k_{ET}^{TT}[\text{methylglyoxal}]}{k_{ET}^{TT}[\text{methylglyoxal}] + k_d} \quad (8)$$

Using the experimentally determined 4.2- μ s lifetime for triplet acetone in nitrogen-purged acetonitrile and a rate constant for triplet to triplet energy transfer of $1 \times 10^{10} \text{ M}^{-1} \text{ s}^{-1}$,³⁷ the ϕ_{ET} at $4.0 \times 10^{-4} \text{ M}$ added methylglyoxal was calculated to be equal to 0.94. The total integrated phosphorescence intensity from **3** was 0.57 ± 0.10 times that for tetramethyldioxetane after correction was made for the efficiency of energy transfer (ϕ_{ET}). The total excited state yield for **3** is thus $(17 \pm 3)\%$ based on an excited triplet state yield from tetramethyldioxetane of 30%.

A summary of the yields and multiplicities of the excited states from the thermolysis of **3** is given in Table IV.

Conclusion

3-Acetyl-4,4-dimethyl-1,2-dioxetane (**3**) occupies a unique position in the gamut of variously substituted 1,2-dioxetanes. The 3-acetyl substituent represents the first instance of an electron-withdrawing substituent on a 1,2-dioxetane. More importantly, its thermolysis is the only known chemiluminescent reaction which produces an α -dicarbonyl compound excited state. Further, it is the first dissymmetric dioxetane in which the partitioning of the excitation energy between two dissimilar carbonyl-containing fragments produced during the thermolysis has been quantitatively determined.^{17d} The salient features of the thermolysis are the moderate efficiency ($17 \pm 3\%$) for forming excited states compared to other dioxetanes,² the high yield of excited singlet methylglyoxal, and the observed low ratio of triplet to singlet excited states of methylglyoxal (9 ± 3). These features are best, though not exclusively, interpretable in terms of a biradical decomposition pathway for dioxetane **3**.

Figure 5 is an energy profile for the suggested thermally induced biradical decomposition pathway for **3**. Benson group equivalent calculations³⁸ indicate that the enthalpy of the net reaction of **3** to form ground-state products (ΔH_r) is ca. -60 kcal/mol . Thus the transition state is estimated to be ca. 86 kcal/mol above the ground state of the products by summation

Table IV. Excited-State Product Yields and Multiplicities from the Thermolysis of Dioxetane **3**

total yield of excited states	O^{*1}	H^{*1}	H^{*1}
$17 \pm 3\%$	$0.45 \pm 0.20\%$	$1.6 \pm 0.5\%$	$15 \pm 3\%^a$

^a Yield represents the difference between the total yield of excited states and the sum of the triplet acetone and singlet methylglyoxal yields.

of the experimentally determined activation energy ($E_a = 26.0 \pm 1.0 \text{ kcal/mol}$) and the calculated enthalpy of reaction (ΔH_r). This estimated total exothermicity from the transition state is sufficient to produce any of the four potential $n\pi^*$ excited states of the products, although it is minimal for the production of acetone singlet. No experimental estimate of the depth of the potential energy well for the expected biradical intermediate (ΔE_1) or for the height of the activation barrier for the path leading from the biradical to excited-state carbonyl products (ΔE_1) is available. Goddard and Harding¹³ have calculated that the transoid $\cdot\text{OCH}_2\text{CH}_2\text{O}\cdot$ biradical from dioxetane lies 14 kcal/mol above the ground state of dioxetane itself. They have also estimated the total energy difference separating the lowest and highest of the eight lowest energy biradical states to be on the order of 3 kcal/mol . If the depth of the potential well for the suspected biradical intermediate from dioxetane **3** is on the order of several kilocalories per mole, then the activation barrier leading from the biradical to singlet acetone may be considerable, thus suggesting a reason for the lack of detectable singlet acetone from thermolysis of **3**. The activation barriers for those pathways leading to excited triplet acetone and excited singlet and triplet methylglyoxal, all of which are observed from the thermolysis of **3**, must be lower than that for formation of singlet acetone. Moreover, the relative heights of the activation barriers for product formation, indicated by the observed product yields, parallel the energies of the product states formed.

The ratio of triplet to singlet excited methylglyoxal formed from dioxetane **3** is small compared to that from nearly all other alkyl-substituted dioxetanes which have been prepared.² This ratio for dioxetane **3** is approaching the statistical limit of three, indicating that there is very little spin selection in the postulated biradical intermediate. This surprising finding suggests that there is no predilection for formation of $n\pi^*$ triplet states due to a special spin-orbit coupling during the reaction.^{9c} Adamantylideneadamantane-1,2-dioxetane is another case in point. The high activation energy for the thermal decomposition (ca. 37 kcal/mol)^{10c} places the transition state perhaps 10 kcal/mol higher in energy than adamantanone excited singlet. The experimentally observed ratio of triplet to singlet adamantanone from adamantylideneadamantane-1,2-dioxetane was 7.5. Thus the normally observed high ratio of triplet to singlet excited states for 1,2-dioxetane decompositions may be due to the relative positioning of the energies of the excited states and the transition state leading out of the proposed biradical intermediate. For tetramethyldioxetane formation of singlet acetone from the suspected biradical requires significantly more energy than formation of triplet acetone. Thus a high ratio of triplets to singlets may be expected. For dioxetane **3** formation of both singlet and triplet methylglyoxal from the biradical intermediate is very exothermic. The much decreased triplet to singlet ratio from **3** compared to other dioxetanes is possibly a result of this arrangement of state energies. However, even in the cases of adamantylideneadamantane-1,2-dioxetane and dioxetane **3**, some selection for triplet states is evidenced. These small se-

lections may be accounted for by geometric or Franck–Condon factors or by some nonequilibrium partitioning among the eight available states in the presumed biradical intermediate. These findings do indicate that a special mechanistic feature is not needed to explain the large ratio of triplet to singlet excited states formed during the thermolysis of typical dioxetanes.

Experimental Section

General. All chemiluminescence measurements were made using the photon-counting technique. Light signals were detected with an EMI 9813B photomultiplier tube and spectral resolution was obtained with a Jarrel Ash 0.25 M monochromator. Constant cell temperature was maintained to ± 0.1 °C within each run using a constant-temperature circulating bath. In a typical experiment, 2 mL of the appropriate solution was added to a 10-mm path length Pyrex cell which was sealed by means of a Teflon stopcock. The cell was placed in the cell holder and allowed to reach thermal equilibrium before measurements were made. Gas chromatographic analyses were carried out using a Varian Aerograph Model 2700 chromatograph equipped with flame ionization detectors. NMR spectra were recorded on a Varian Associates EM-390 instrument with tetramethylsilane as internal standard. IR spectra were obtained with a Perkin-Elmer Model 237B grating infrared spectrophotometer. UV absorption spectra were recorded either on a Perkin-Elmer Model 202 or a Cary 14 spectrometer. Elemental analyses were performed by the Analyses Laboratory, Department of Chemistry, University of Illinois, Urbana, Ill.

Materials. Acetonitrile (Aldrich spectrophotometric grade) was first dried by stirring over calcium hydride and was then distilled from calcium hydride through a 30-cm Vigreux column. The first 10% of the distillate was discarded. Carbon tetrachloride (Mallinckrodt spectrophotometric grade) was photolyzed through Pyrex for 3 h in the presence of benzophenone to remove sources of abstractable hydrogen, and was then distilled through a 30-cm Vigreux column. Benzene (Burdick and Jackson Laboratories Inc., distilled in glass) was shaken with concentrated sulfuric acid, separated, passed through a basic alumina column, and then distilled.

9,10-Dibromoanthracene (DBA) (Aldrich) was recrystallized from acetonitrile. 9,10-Diphenylanthracene (DPA) (Aldrich) was used without further purification. Rubrene (Aldrich) was chromatographed on neutral alumina using benzene as the eluent. The purified rubrene was then recrystallized from benzene (purified as described above) prior to use.

4-Bromo-3-hydroxy-3,5,5-trimethyl-1,2-dioxolane (2). Careful! This compound has decomposed explosively on distillation. Anhydrous ethereal H_2O_2 was prepared by the addition of anhydrous Na_2SO_4 to a solution of 14 mL of 90% H_2O_2 in 65 mL of ether under nitrogen. The solution was stirred magnetically at room temperature for 0.5 h and then decanted into a round-bottom flask which had been flushed with nitrogen. The volume was reduced to ca. 40 mL by blowing dry nitrogen over the ether solution. The solution was cooled to -60 °C and 7.0 g (71.3 mmol) of mesityl oxide in 10 mL of ether was then added dropwise. 1,3-Dibromo-5,5-dimethylhydantoin (10.2 g, 35.6 mmol, J. T. Baker) was added slowly to the reaction solution with vigorous stirring. The resulting mixture was warmed to room temperature and stirred for an additional 30 min. The reaction mixture was washed with seven 20–25-mL portions of saturated aqueous K_2CO_3 . The water fractions were back-extracted with ether. The ether extracts were combined, dried over anhydrous MgSO_4 , filtered, and then concentrated in vacuo.

Vacuum distillation of the liquid yielded 11.9 g (bp 71–75 °C (1.2 mm), 80%) of a 60:40 mixture of the diastereomers (based on NMR integration of the methine protons) of the 1,2-dioxolane **2**. Iodometric titration showed an active oxygen content of (7.4 ± 0.2)% (average of two trials): NMR (CCl_4) δ 4.35 (s, 1 H), 4.18 (s, 1 H), 3.75 (broad, exchangeable with D_2O , 2 H), 1.6, 1.55, and 1.45 (series of singlets, 18 H); IR (CCl_4) 3700, 1390, 1380, and 880 cm^{-1} ; mass spectrum (70 eV) m/e (rel intensity) 212, 210 (7), 179 (48), 177, 136 (70), 134, 111 (12), 108 (10), 99 (100).

Anal. Calcd for $\text{C}_6\text{H}_{11}\text{O}_3\text{Br}$: C, 34.14; H, 5.25; Br, 37.86. Found: C, 34.46; H, 5.03; Br, 37.87.

3-Acetyl-4,4-dimethyl-1,2-dioxetane (3). To a solution of 884 mg (4.19 mmol) of 4-bromo-3-hydroxy-3,5,5-trimethyl-1,2-dioxolane (**2**) in 35 mL of CH_2Cl_2 at 12 °C was added 509 mg (4.54 mmol) of potassium *tert*-butoxide. The mixture was stirred vigorously at 12 °C

for 3 min and then suction filtered through a coarse frit sintered glass funnel. The filtrate was concentrated in vacuo to ca. 2 mL and 3 mL of cold pentane was added. The resulting solution was transferred to a jacketed chromatography column containing 17 g of silica gel at -22 °C. The yellow band due to the dioxetane was eluted with 3% ether in pentane. The chemiluminescence was used to monitor the chromatography. The fractions containing dioxetane **3** were separately concentrated in vacuo, combined, diluted with ice-cold CCl_4 and reconcentrated in vacuo until the remaining pentane was removed (NMR). The CCl_4 solution was bulb to bulb distilled at 2×10^{-5} mm after three freeze–pump–thaw cycles. The distilled CCl_4 solution was then concentrated in vacuo to remove acetone and methylglyoxal and diluted to 10 mL with ice-cold CCl_4 . The resulting solution was determined to be 0.031 M by NMR (40 mg, 7.3%). The concentration was also determined iodometrically. A 0.4-mL aliquot of **3** in CCl_4 was added to a solution consisting of 5 mL of citric acid/*tert*-butyl alcohol and 0.5 mL of $\text{KI}/\text{Na}_2\text{CO}_3$ ³⁸ under nitrogen. Titration of the sample after 5 min with 0.01 N sodium thiosulfate to a clear end point gave a concentration of 0.029 ± 0.002 M (96%). Acetonitrile solutions of **3** were prepared as above except for the following modifications. The pentane/ether solution of **3** from the chromatography was concentrated in vacuo, diluted with CH_3CN , and then reconcentrated in vacuo to remove the remaining pentane/ether (determined by VPC). The CH_3CN solution of **3** was then bulb to bulb distilled at 2×10^{-5} mm after three freeze–pump–thaw cycles. The distilled solution of **3** was dried under nitrogen with anhydrous K_2CO_3 , concentrated in vacuo to remove acetone and methylglyoxal, and diluted to known volume with CH_3CN . Concentrations of **3** in acetonitrile were determined by UV absorption at 350 nm. Analysis at 350 nm avoided potential interference from acetone or methylglyoxal absorption since acetone does not absorb at 350 nm and the absorption spectrum of methylglyoxal has a window in this region. The isolated yield of dioxetane **3** in CH_3CN was 9.4%: NMR (CCl_4) δ 4.93 (s, 1 H), 2.40 (s, 3 H), 1.73 (s, 3 H), 1.32 (s, 3 H); IR (CCl_4) 1725, 1375, 1360, 1155 cm^{-1} ; UV λ_{max} (CCl_4) 290 nm (ϵ 54), 350 (17); λ (90% $\text{CH}_3\text{CN}/10\% \text{CCl}_4$) 350 nm (ϵ 15).

4-Acetyl-5,5-dimethyl-2,2,2-triethoxy-1,3,2-dioxaphospholane (4). To a 1-mL aliquot of dioxetane **3** (0.0385 M, CCl_4 , 0.0385 mmol) at 0 °C under nitrogen was added 6.5 μL (0.038 mmol) of $(\text{EtO})_3\text{P}$ which had been distilled over sodium. The mixture was stirred vigorously at 0 °C for 7 min. The phospholane **4** was relatively stable in solution at room temperature under nitrogen ($t_{1/2} > 10$ h at 23 °C) but the CCl_4 could not be removed, either by concentration in vacuo or by passing dry nitrogen over the reaction mixture, without decomposition. The NMR spectrum of the reaction mixture indicated the presence of acetone, triethyl phosphate, and the phospholane **4**: 220-MHz NMR (CCl_4) δ 3.86 (m, $J_{\text{HH}} \approx J_{\text{PH}} = 7.0$ Hz, 6 H), 3.68 (s, 1 H), 1.39 (s, 3 H), 1.19 (sextet, $J_{\text{HH}} = 7.0$, $J_{\text{PH}} = 1.5$ Hz, 9 H), 1.02 (s, 3 H).

Methylglyoxal (2-Oxopropanal). Methylglyoxal was prepared by a modification of the procedure of Coveleskie and Yardley.¹⁹ Methylglyoxal (40% aqueous solution) was obtained from Aldrich Chemical Co. The sample was first concentrated by removal of the water by vacuum distillation (25–30 °C, 0.5 mm). The thick brown residue which remained was heated to 170 °C at 0.5 mm. The vapor was first passed through a trap cooled to -50 °C and then through Drierite at room temperature to remove water vapor and less volatile components. Lastly, the methylglyoxal was collected in a trap cooled to -196 °C. The methylglyoxal was stored under nitrogen at -196 °C until used. NMR spectra showed no trace of glyoxal, biacetyl, or other impurities: NMR (CCl_4) δ 9.07 (s, 1 H), 2.25 (s, 3 H). Solutions of methylglyoxal in CH_3CN or CCl_4 were prepared at 0 °C and stored at -20 °C until used. All luminescence measurements using methylglyoxal were made within 6 h of its preparation.

6-Methyl-endo-6-phenylbicyclo[3.1.0]hex-3-en-2-one (5). The lumiketone **5** was prepared according to the procedure of Zimmerman et al.²⁶ with the following modifications. A nitrogen-purged solution of 4-methyl-4-phenylcyclohexadienone (275 mg, 1.49 mmol) in 350 mL of acetone (Burdick and Jackson Laboratories, Inc., distilled in glass) was irradiated for 2 h through quartz using low-pressure mercury lamps in a Rayonet. The solvent was removed in vacuo to give 259 mg of a clear oil. The crude photolysate was diluted with CCl_4 and extracted with 10% aqueous NaOH . Preparative gas chromatography (0.25 in. \times 8 ft, 8.4% SE-30, 170 °C) yielded material whose NMR spectrum was consistent with that previously reported for 6-methyl-endo-6-phenylbicyclo[3.1.0]hex-3-en-2-one (**5**).

Chemical Trap of Triplet Acetone from Dioxetane 3 with 4-Methyl-4-phenylcyclohexadienone (4). Solutions of dioxetane 3 or tetramethyldioxetane and 4-methyl-4-phenylcyclohexadienone (4) in acetonitrile were prepared in 5-mm o.d. Capillary test tubes with biphenyl as an internal standard. The concentrations of tetramethyldioxetane and dioxetane 3 ranged between 0.15 and 0.29 M. The concentrations of 4-methyl-4-phenylcyclohexadienone (4) ranged between 1.7 and 3.0 M. Corrections to the concentrations were made for the volume change upon dissolution of the dienone 4 in CH₃CN. The tubes were sealed and heated at 72–76 °C for 3.5 h. Analysis for lumiketone 5 was made by gas chromatography (0.125 in. × 6 ft, SE-30 on Chromosorb Q at 170 °C). The results are shown in Table III.

Acknowledgment. This work was supported in part by the Office of Naval Research, in part by the National Science Foundation, and in part by the donors of the Petroleum Research Fund, administered by the American Chemical Society.

References and Notes

- (1) Fellow of the Alfred P. Sloan Foundation, 1977–1979.
- (2) T. Wilson, *MTP Int. Rev. Sci.: Phys. Chem., Ser. Two*, **9**, 265 (1976).
- (3) K. R. Kopecky and C. Mumford, *Can. J. Chem.*, **47**, 709 (1969).
- (4) Though the high ratio >50:1 for triplet to singlet products from tetramethyl-1,2-dioxetane⁵ and other dioxetanes⁶ has been well established, there has been one notable exception, namely, 3,4-dimethyl-3,4-di-*n*-butyl-1,2-dioxetane (¹φ = 0.05, ³φ = 0.035).⁷ The triplet to singlet product ratio for this dioxetane has recently been revised showing a relatively high triplet yield (¹φ = 0.008, ³φ = 0.25),⁸ making it consistent with other dioxetane decompositions.
- (5) N. J. Turro and A. Lechtken, *J. Am. Chem. Soc.*, **94**, 2886 (1972).
- (6) P. Lechtken, G. Reissenweber, and P. Grubmüller, *Tetrahedron Lett.*, 2881 (1977).
- (7) T. R. Darling and C. S. Foote, *J. Am. Chem. Soc.*, **96**, 1625 (1974).
- (8) E. J. H. Bechara, A. L. Baumstark, and T. Wilson, *J. Am. Chem. Soc.*, **98**, 4648 (1976).
- (9) (a) F. McCapra, *Chem. Commun.*, 155 (1969); (b) D. R. Kearns, *J. Am. Chem. Soc.*, **91**, 6654 (1969); (c) N. J. Turro and P. Lechtken, *ibid.*, **95**, 264 (1973); (d) N. J. Turro and A. Devaquet, *ibid.*, **97**, 3859 (1975).
- (10) (a) W. H. Richardson, F. C. Montgomery, M. B. Yelvington, and H. E. O'Neal, *J. Am. Chem. Soc.*, **96**, 7525 (1974); (b) W. H. Richardson, F. C. Montgomery, P. Slusser, and M. B. Yelvington, *ibid.*, **97**, 2819 (1975); (c) G. B. Schuster, N. J. Turro, H.-C. Steinmetzer, A. P. Schaap, G. Faber, W. Adam, and J. C. Liu, *ibid.*, **97**, 7110 (1975).
- (11) J.-y. Koo and G. B. Schuster, *J. Am. Chem. Soc.*, **99**, 5403 (1977).
- (12) I. Simo and J. Stauff, *Chem. Phys. Lett.*, **34**, 326 (1975).
- (13) L. B. Harding and W. A. Goddard III, *J. Am. Chem. Soc.*, **99**, 4520 (1977).
- (14) Efficient generation of excited singlet states by a chemically initiated electron exchange luminescence (CIEEL) mechanism has recently been observed for diphenoyl peroxide (J.-y. Koo and G. B. Schuster, *J. Am. Chem. Soc.*, **99**, 6107 (1977)) and dimethyldioxetanone (S. P. Schmidt and G. B. Schuster, *ibid.*, **100**, 1966 (1978)).
- (15) A. L. Thayer and A. P. Schapp, Abstracts, 174th National Meeting of the American Chemical Society, Chicago, Ill., Aug 1977.
- (16) H. E. Zimmerman, G. E. Keck, and J. L. Pflederer, *J. Am. Chem. Soc.*, **98**, 5574 (1976).
- (17) (a) W. H. Richardson, F. C. Montgomery, M. B. Yelvington, and G. Ranney, *J. Am. Chem. Soc.*, **96**, 4045 (1974); (b) W. H. Richardson, F. C. Montgomery, and M. B. Yelvington, *ibid.*, **94**, 9277 (1972); (c) W. H. Richardson, M. B. Yelvington, and H. E. O'Neal, *ibid.*, **94**, 1619 (1972); (d) F. McCapra, I. Beheshti, A. Burford, R. A. Hann, and K. A. Zaklika, *J. Chem. Soc., Chem. Commun.*, 944 (1977).
- (18) K. R. Kopecky, J. E. Filby, C. Mumford, P. A. Lockwood, and J.-y. Ding, *Can. J. Chem.*, **53**, 1103 (1975).
- (19) R. A. Coveleskie and J. T. Yardley, *J. Am. Chem. Soc.*, **97**, 1667 (1975).
- (20) (a) T. Wilson and A. P. Schaap, *J. Am. Chem. Soc.*, **93**, 4126 (1971); (b) H.-C. Steinmetzer, A. Yekta, and N. J. Turro, *ibid.*, **96**, 282 (1974).
- (21) P. S. Engel and B. M. Monroe, *Adv. Photochem.*, **8**, 245 (1971).
- (22) M. R. Padye, S. P. McGlynn, and M. Kasha, *J. Chem. Phys.*, **24**, 588 (1956).
- (23) (a) T. Wilson and A. P. Schaap, *J. Am. Chem. Soc.*, **93**, 4126 (1971); (b) V. A. Belakov and R. F. Vassilev, *Photochem. Photobiol.*, **11**, 179 (1970).
- (24) There is some recent evidence indicating that the energy transfer from acetone triplet to DBA occurs by a diffusion-controlled triplet to triplet energy transfer to the second excited triplet of DBA followed by a rapid intersystem crossing to the first excited singlet; see R. Schmidt, H. Kelm and H.-D. Brauer, *Ber. Bunsenges. Phys. Chem.*, **81**, 402 (1977).
- (25) N. J. Turro, H.-C. Steinmetzer, and A. Yekta, *J. Am. Chem. Soc.*, **95**, 6468 (1973).
- (26) H. E. Zimmerman and G. Jones II, *J. Am. Chem. Soc.*, **92**, 2753 (1970).
- (27) N. J. Turro, A. Lechtken, G. Schuster, J. Orell, H.-C. Steinmetzer, and W. Adam, *J. Am. Chem. Soc.*, **96**, 1627 (1974).
- (28) P. J. Wagner, *J. Am. Chem. Soc.*, **89**, 5715 (1967); P. J. Wagner and I. E. Kochevar, *ibid.*, **90**, 2232 (1968); R. S. H. Liu, *ibid.*, **90**, 1899 (1968); see also N. J. Turro and P. Lechtken, *Tetrahedron Lett.*, 565 (1973).
- (29) T. Wilson, D. E. Golan, M. S. Harris, and A. L. Baumstark, *J. Am. Chem. Soc.*, **98**, 1086 (1976).
- (30) The lifetime of triplet acetone from tetramethyldioxetane in carbon tetrachloride solution was determined to be ca. 18 ns by a Stern-Volmer quenching analysis using DBA, suggesting that carbon tetrachloride is an efficient quencher of triplet acetone. Therefore, all measurements were carried out in acetonitrile solution.
- (31) E. H. White, P. D. Wildes, J. Wiecko, H. Doshan, and C. C. Wei, *J. Am. Chem. Soc.*, **95**, 7050 (1973).
- (32) The absence of a CIEEL component to the chemiluminescence from dioxetane 3 was indicated by the lack of a rate acceleration with added aromatic hydrocarbon (rubrene).
- (33) The lifetimes were calculated using a value of $6 \times 10^{10} \text{ M}^{-1} \text{ s}^{-1}$ for the rate of singlet to singlet energy transfer in benzene; see N. J. Turro, A. Lechtken, G. Schuster, J. Orell, H.-C. Steinmetzer, and W. Adam, *J. Am. Chem. Soc.*, **96**, 1627 (1974).
- (34) This number represents a mean value based on the yields reported in N. J. Turro and P. Lechtken, *J. Am. Chem. Soc.*, **94**, 2886 (1972); W. Adam, N. Duran, and G. A. Simpson, *ibid.*, **97**, 5464 (1975).
- (35) Phosphorescence intensities were measured at 530 nm.
- (36) A. A. Lamola and G. S. Hammond, *J. Chem. Phys.*, **43**, 2129 (1965).
- (37) H. L. J. Bäckstrom and K. Sandros, *Acta Chem. Scand.*, **18**, 48 (1960).
- (38) S. W. Benson, F. R. Cruickshank, D. M. Golden, G. R. Haugen, H. E. O'Neal, A. S. Rodgers, R. Shaw, and R. Walsh, *Chem. Rev.*, **69**, 279 (1969).
- (39) F. C. Montgomery, R. W. Larson, and W. H. Richardson, *Anal. Chem.*, **45**, 2258 (1973).